



**MOTY- KO Model #'s
14DD/18HD**

**CORDLESS HAMMER DRILL / DRILL
INSTRUCTION MANUAL**

LMD, LLC.

www.motyko.com

1445 Brookville Way, Suite J, Indianapolis, IN 46239

TEL: 317-322-5265

FAX: 317-322-5205

WARNING:

Please read the following instruction carefully before the tool used.

GENERAL SAFETY RULES

PERSONAL SAFETY

1. **USE SAFETY GLASSES.** Use a face or dust mask if operation is dusty.
2. **DRESS PROPERLY.** Do not wear loose clothing or jewelry. They can be caught in moving parts. Rubber gloves and non-skid footwear are recommended when working outdoors. Wear protective hair covering to contain long hair.
3. **STAY ALERT.** Watch what you are doing. Use common sense. Do not operate tool when you are tired.
4. **REMOVE ADJUSTING KEY & WRENCHES.** From habit of checking to see that keys and adjusting wrenches are removed from tool before turning it on.
5. **CHECK DAMAGED PARTS.** Before further use of tool, a guard or other part that is damaged should be carefully checked to determine that it will operate properly and perform its intended function. Check for alignment of moving parts, binding of moving parts, breakage of parts, mounting, and any other conditions that may affect its operation. A guard or other part that is damaged should be properly repaired or replaced by and authorized service center unless otherwise indicated elsewhere in this instruction manual. Have defective switches replaced by authorized service center. Do not use tool if switch does not turn it on and off.
6. **DO NOT OVERREACH.** Keep proper footing and balance at all times.

WORK AREA

1. **KEEP WORK AREA CLEAN.** Cluttered areas and benches invite injuries.
2. **CONSIDER WORK AREA ENVIRONMENT.** Don't expose power tools to rain. Don't use power tools in damp or wet locations. Keep work area well lit.
3. **GUARD AGAINST ELECTRIC SHOCK.** Prevent body contact with grounded surfaces; for example, pipes, radiators, ranges, and refrigerator enclosures.
4. **KEEP CHILDREN AWAY.** All visitors should be kept away from work area. Do not let visitors contact tool.
5. **DO NOT OPERATE** portable electric tools near flammable liquids or in gaseous or explosive atmospheres. Motors in these tools normally spark, and the sparks might ignite fumes.
6. **USE EXTREME CAUTION.** When drilling or driving into wall, ceilings or other areas where electrical wire may be contact. The metal portions of tools are not insulated from the driver spindle. Be careful not to touch any exposed electrical terminals with the tool.

TOOL AND CHARGER USE

1. **DON'T FORCE TOOL.** It will do the job better and safer at the rate for which it was intended.
2. **USE RIGHT TOOL.** Don't force small tool or attachment to do the job of a heavy-duty tool. Don't use tool for purpose not intended; for example, don't use circular saw for cutting tree limbs or logs.
3. **SECURE WORK.** Use clamps or a vise to hold work. It's safer than using our hand and it frees both hands to operate tool.
4. **MAINTAIN TOOLS WITH CARE.** Keep tools sharp and clean for better and safe performance. Follow instructions for lubricating and changing accessories. Keep handles dry, clean, and free from oil and grease.
5. **DISCONNECT OR LOCK OFF TOOLS.** When not in use, before servicing, and when changing accessories, such as blades, bits, cutters.
6. **AVOID UNINTENTIONAL STARTING.** Be careful not to activate the switch when charging accessories, or carrying the tool. To prevent damaged to charger, do not run the tool with the charger connected.

TOOL AND CHARGER CARE

1. **STORE IDLE TOOLS.** When not in use, tools should be stored in dry, high or secured place - out of the reach of children.
2. **DON'T ABUSE CORD.** Never carry charger by cord or yank it to disconnect from receptacle. Keep cord from heat, oil, and sharp edges.
3. **DO NOT ALTER OR MISUSE TOOL.** These tools are precision built. Any alteration or modification is misuse and may result in a dangerous condition.
4. **MAINTAIN TOOLS WITH CARE.** Keep tools clean for better and safer performance. Follow instructions for lubricating and changing accessories. Inspect charger cords periodically and if damaged, have repaired by authorized service facility. Inspect extension cords periodically and replace if damaged. Keep handles dry, clean and free from oil and grease.

IMPORTANT SAFETY INSTRUCTIONS FOR BATTERY CHARGER

Before using charger, read all instructions and cautionary marking on charger, battery pack, and product using battery pack.

WARNING: 120 volts or 230 volts present at charging terminal. Do not probe with conductive objects. Danger of electric or electrocution.

WARNING: If battery pack case is cracked or damaged, do not inset into charger. Danger of electric or electrocution.

1. The charger and battery pack is specially designed to work together. DO NOT attempt to charge the battery pack with any other chargers.
2. Do not expose charger to rain or snow.
3. The charger is not intended for any uses other than charging MOTY-KO rechargeable batteries. Any other uses may result in risk of fire, electric shock or electrocution.
4. To reduce risk of damage to electric plug and cord, pull by plug rather than cord when disconnecting charger.
5. Make sure cord is located so that it will not be stepped on, tripped over, or otherwise subjected to damage or stress.
6. An extension cord should not be used unless absolutely necessary. Use of improper extension cord could result in risk of fire, electric shock, or electrocution.
7. An extension cord must have adequate wire size (AWG or American Wire Gauge) for safety. When using more than one extension to make up the total length, be sure each individual extension contains at least the minimum wire size.

Recommended Minimum AWG Size for Extension Cords

Total Extension Cord Length (feet)

25	50	75	100	125	150	175
----	----	----	-----	-----	-----	-----

Wire Gauge

18	18	16	16	14	14	12
----	----	----	----	----	----	----

8. The charger is ventilated through slots in the top and the bottom of the housing. Do not place any object on top of charger or place the charger on a soft surface that might block the ventilation slots and result in excessive internal heat. Place the charger in a position away from any heat source.
9. Do not operate charger with damaged cord or plug - have them replace immediately.
10. Do not operate charger if it has received a sharp blow, been dropped, or

otherwise damaged in any way; take it to an authorized service center.

11. Do not disassemble charger; take it to an authorized service center when service or repair is required. Incorrect reassemble may result in a risk of electric shock, electrocution or fire.
12. To reduce risk of electric shock, unplug charger from outlet before attempting any cleaning. Removing the battery pack will not reduce this risk.
13. **NEVER** attempt to connect 2 chargers together.
14. **DO NOT** store or use the tool and battery pack in locations where the temperature may reach or exceed 105°F (such as outside sheds or metal buildings in summer).
15. The charger is designed to operate on standard household electrical power. Do not attempt to use it on any other voltage!

IMPORTANT SAFETY INSTRUCTIONS FOR BATTERY PACKS

1. The battery pack is not fully charged out of the carton! First read the safety instructions below. Then follow charging notes and procedures.
2. Do not incinerate the battery pack even if it is severely damaged or is completely worn out. The battery pack can explode in a fire.
3. A small leakage of liquid from the battery pack cells may occur under extreme usage or temperature conditions. This does not indicate a failure. However, if the outer seal is broken and this leakage gets on your skin:
 - a. Wash quickly with soap and water.
 - b. Neutralize with a mild acid such as lemon juice or vinegar.
 - c. If battery liquid gets into your eyes, flush them with clean water for a minimum of 10 minutes and seek immediate medical attention. (Medical note: The liquid is 25-35% solution of potassium hydroxide.)
4. Never attempt to open the battery pack for any reason. If the plastic housing of the battery pack breaks or cracks, immediately discontinue use and do not recharge.
5. Do not carry extra battery packs in aprons, pockets, or toolboxes along with their metal objects. Battery packs could be short-circuited causing damage to the battery pack and possibly causing severe burns or fire.
6. Charge the battery packs only in MOTY-KO chargers.
7. **NOTE:** Review and observe all of the "Important Charging Notes" in the charger instruction section of this manual.
8. **NOTE:** The batteries in your battery pack are the nickel-cadmium types. Cadmium is considered to be a toxic material by the Environmental

Protection Agency. Before disposing of damaged or worn out Nickel-Cadmium battery packs, check with your state Environmental Protection Agency to find out about special restrictions on the disposal of these battery packs or return them to a MOTY-KO certified service center for recycling.

IMPORTANT CHARGING NOTES

1. Do not charge the tool in damp or wet environment.
2. Longest life and best performance can be obtained if the battery pack is charged when the air temperature is between 32°F and 113°F(0 -45°C). DO NOT charge the battery pack in an air temperature below +32°F(+0°C), or above +113°F(+45°C) . This is important and will prevent serious damage to the battery pack.
3. The charger and battery pack may become warm to touch while charging. This is a normal condition, and does not indicate a problem.
4. To prevent overheating, do not cover the charger and do not charge battery packs in direct sunlight or near heat sources.
5. If the battery pack does not charge properly
 - (1) Check current at receptacle by plugging in a lamp or other appliance.
 - (2) Check to see if receptacle is connected to a light switch, which turns power off when you turn out the lights.
 - (3) Move charger and battery pack to a location where the surrounding air temperature is approximately 32°F - 113°F(0 -45°C).
 - (4) If charging problems persist, take or send the tool, battery pack and charger to your local service center.
6. The battery pack should be recharged when it fails to produce sufficient power on jobs, which were easily done previously. **DO NOT CONTINUE** to use under these conditions. Follow the charging procedure. You may also charge a partially used pack whenever you desire with no adverse affect on the battery pack.
7. Under certain conditions, with the charger plugged in to the power supply, the exposed charging contacts inside the charger can be shorted by foreign material. Foreign materials of a conductive nature such as, but not limited to, steel wool, aluminum foil, or any buildup of metallic particles should be kept away from charger cavities. Always unplug the charger from the power supply when there is no battery pack in the cavity. Unplug charger before attempting to clean.
8. Do not freeze or immerse charger in water or any other liquid.

WARNING: Don't allow any liquid to get inside charger. Electric shock may result. To facilitate the cooling of the battery pack after use, avoid placing

the charger or battery packs in a warm environment such as in a metal shed, or an uninsulated trailer.

CAUTION: Never attempt to open the battery pack for any reason. If the plastic housing of the battery pack breaks or cracks, return to a service center for recycling.

IMPORTANT: This product is not user serviceable. There are no user serviceable parts inside the charger. Servicing at an authorized service center is required to avoid damage to static sensitive internal components.

READ ALL OF THE INSTRUCTIONS IN THE BATTERY CHARGER SECTION OF THIS MANUAL BEFORE ATTEMPT TO CHARGE THE BATTERY PACK FOR YOUR TOOL.

Always use correct battery pack (pack supplied with tool or replacement pack exactly like it.) Never install any other battery pack. It will ruin your tool and may create a hazardous condition.

INTRODUCTION:

These unite have the idea speed and torque combination required for both drilling and screw driving application. To get an optimum performance and protect your self, please read the following instruction carefully to get before the tool used.

FEATURES

VARIABLE SPEED SWITCH

The variable speed switch provides safety feature to the user for screw driving. To turn the tool on, squeeze the trigger switch. To turn the tool off, release the trigger switch (**see Fig. 1A**). Your tool is equipped with a brake. The chuck will stop as soon as the trigger switch is fully released. The variable speed switch enables you to select the best speed for a particular application. The farther you squeeze the trigger, the faster the tool will operate. Use lower speeds for starting holes without a center punch, drilling metals or plastic, driving screws and drilling ceramics, or in any application requiring high torque. Higher speeds are better drilling in wood,wood compositions and for using abrasive and polishing accessories. For maximum tool life, use variable speed only for starting holes or fasteners.

NOTE:Continuous use in variable speed range is not recommended. It may damage the switch and should be avoided.

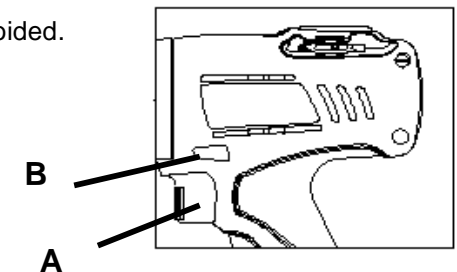

Fig. 1

FORWARD / REVERSE CONTROL BUTTON

A forward/reverse control button determines the direction of the tool and also serves as a lock off button. To select forward rotation, **RELEASE THE TRIGGER SWITCH** (see Fig. 1A), and depress the forward/reverse control button (see Fig. 1B), toward left side of the tool. To select reverse, depress the forward/reverse control button (see Fig. 1B), toward right side of the tool. **The center position of the control button (see Fig.1B) locks the tool in the off position.** When change the position of the control button, making sure the trigger is released.

NOTE: The first time the tool is run after changing the direction of rotation, you may hear a click on start up. This is normal and does not indicate a problem.

TORQUE ADJUSTMENT COLLAR

The clutch feature of your Driver/Drill is an adjustable torque screwdriver mechanism for driving and removing a wide array of fastener shapes and sizes (see Fig. 2). The clutch allows you to instantaneously regulate the torque, based on the force applied.

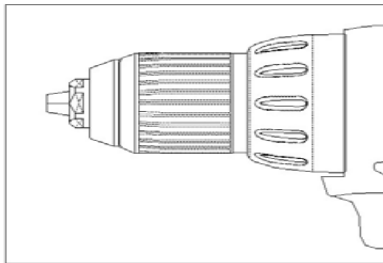

Fig. 2

FOR THE DRILL DRIVER:

Circling the collar are numbers ranging from 1 to 23 and a drill bit symbol. These numbers are used to set the clutch to deliver a torque range. The higher number on the collars, the higher torque and larger the fastener which can be driven. To select any of the numbers, rotate until the desire number aligns with the selector.

DUAL RANGE GEARING

The dual range feature of your Driver/Drill allows you to shift gears for greater versatility. To select the low speed, high torque setting (**position L**), turn the tool off and permit to stop. Push the button forward towards the chuck (see Fig. 3). To select the high speed, low torque setting (**position H**), turn the tool off

and permit to stop. Slide the gear shifter back (away from chuck).

NOTE: Do not change gears when the tool is running. If you are having trouble changing gears, make sure that the dual range gear button is either completely pushed forward or completely pushed back.

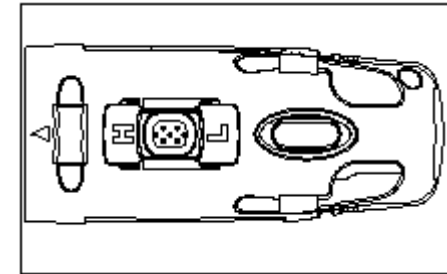

Fig. 3

CLUTCH LOCK

To lock the clutch for drilling operations, simply move the Driver/Drill selector to the "Drill" position as described under "Operation as a Drill"



This symbol indicates the **DRILL POSITION**. To select this mode for high speed drilling (Wood, Aluminum, and Steel) and the clutch will be locked. The trigger has to be released to stop the running motor when the chuck slipping or shaft locked.



To select this mode with high speed provides for masonry or concrete drilling. The trigger has to be released to stop the running motor when the chuck slipping or shaft locked.

INSERTING AND REMOVING DRILL AND SCREWDRIVER BITS

CAUTION

Always set the reversing button to the center (locked "OFF") position when installing and removing bits.

1. The three-jaw chuck is designed for self-centering of the bit. Open jaws large enough by turning the sleeve (A) Fig.4 counterclockwise, when viewing the chuck from the bit end, so that the bit shank can be inserted easily.
2. Clean and insert the smooth end of the bit as far as it will go into the chuck, or up to the flutes for small bits.
3. While holding the bit with one hand, turn the sleeve (A) Fig4

clockwise until the bit is gripped in the chuck.

4. Tighten the chuck by turning the sleeve (A) clockwise. Tighten securely.
5. To remove the bit, reverse procedure.

WARNING

Do not operate the drill motor while installing or removing bits. This action may cause the bit to be thrown from the chuck, causing personal injury.

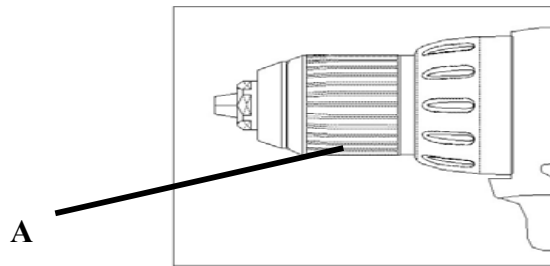

Fig. 4

DRIVER BIT STORAGE

Convenient storage areas with retaining clip, for screwdriver bits are provided on each side of the tool. (See Fig. 5A)

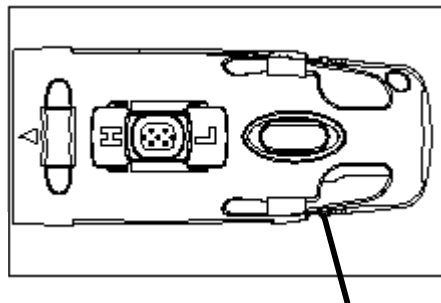

Fig. 5

OPERATION MANUAL

NORMAL CHARGING

Make sure power circuit voltage is the same as that shown on the charger specification plate. Connect charger to power source. The orange light (A) Fig. 6, should light up. This indicates the charger is ready to begin charging.

Position battery pack on charger; align rails (see Fig. 6D), on battery charger with four tabs (see Fig. 7E) on battery pack. Slide battery forward onto charger

until it stops.

The red light (see Fig. 6B), should begin to glow continuously, indicating that the battery pack is receiving a "Fast Charge" (if the red light does not glow continuously, and the green light (see Fig. 6C), begins to glow: remove battery and re-insert when battery temperature is between 32°F(0°C) and 113°F(45°C). After approximately one hour, the "Fast Charge" indicator light (red) should go out indicating that the battery pack is fully charged and that the charger is now in a "Trickle Charge" mode (green light). The battery pack can be left on "Trickle Charge" until you are ready to use it. Depending on room temperature, line voltage, and existing charge level, initial battery charging may take longer than one hour. Disconnect charger from power source when not in use.

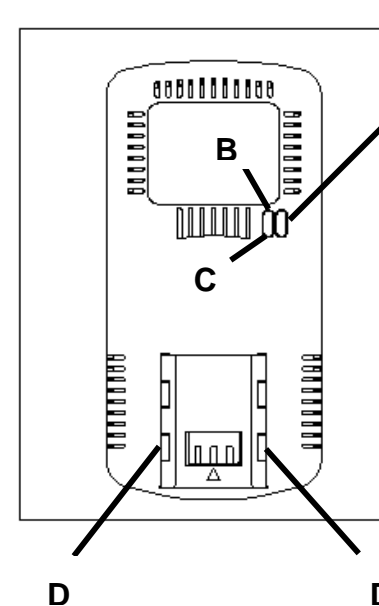

Fig 6

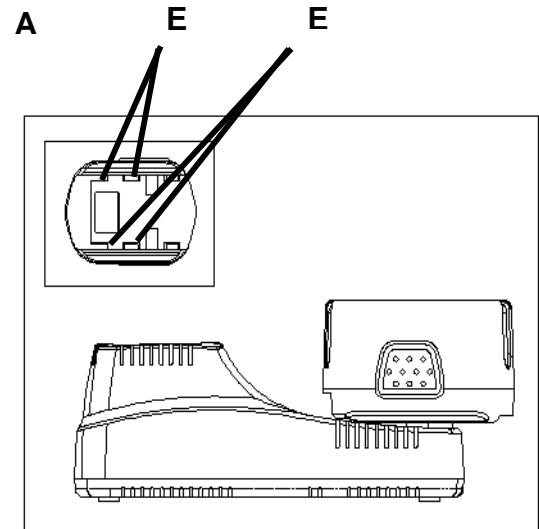

Fig.7

INSTALLING OR REMOVING BATTERY PACK

TO REMOVE BATTERY PACK : Depress the battery release button (see Fig. 8B), and pull battery pack out of tool.

TO INSTALL BATTERY PACK : Align rails (see Fig 8A), on the tool with the four tabs on the battery pack, and push battery pack onto tool until it locks in place.

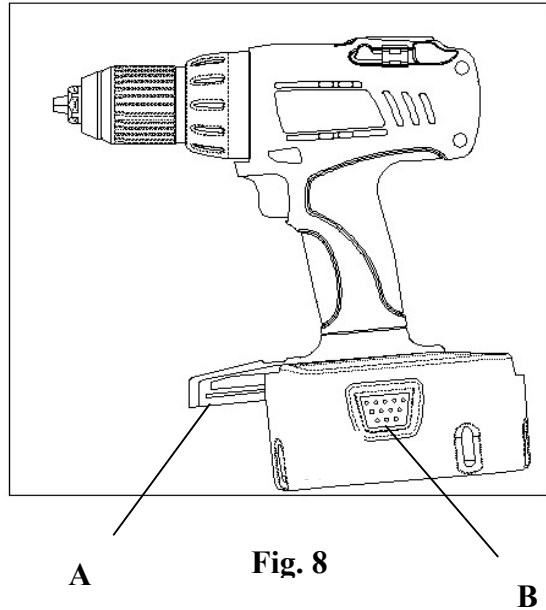

Fig. 8

CHUCK REMOVAL

ALWAYS WEAR EYE PROTECTION

Turn the adjustment collar to the “drill” position and low speed gear shifter. Tighten the chuck around the shorter end of a hex key (not supplied) of 1/4” or greater size. Using a wooden mallet or similar object, strike the longer end in the clockwise direction. This will loosen the screw inside the chuck.

1. Open chuck jaws fully.
2. Insert a screwdriver into front of chuck between jaws to engage screw head. Remove screw by turning clockwise.
3. Place a hex key in chuck and tighten. Using a wooden mallet or similar object, strike key sharply in the counterclockwise direction (see Fig. 9). This will loosen the chuck so that it can be unscrewed by hand.

CHUCK INSTALLATION

1. Screw the chuck on by hand as far as it will go and insert screw (LH thread).
2. Tighten screw securely.
3. Tighten the chuck around the shorter end of a 1/4”a or large hex key (not supplied) strike the longer end in the clockwise direction with a wooden mallet (see Fig. 10).

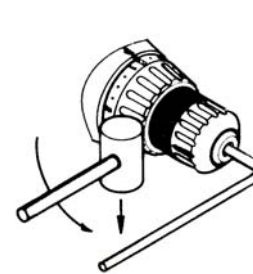

Fig. 9

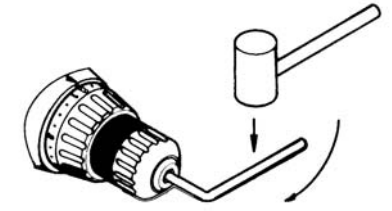

Fig. 10

OPERATION AS A DRILL

Turn the collar to the drill bit symbol. Install and tighten the desired drill bit in the chuck. Select the desired speed/torque range using the dual range gear shifter to match the speed and torque to the planned operation. Follow these instructions for best results when drilling.

DRILLING

Use sharp drill bits only. For WOOD, use twist drill bits, spade bits, power auger bits, or hole saws. For METAL, use high-speed steel twist drill bits, or hole saws. For MASONRY, such as brick, cement, cinder block, etc., use carbide-tipped bits. Be sure the material to be drilled is anchored or clamped firmly. If drilling thin material, use a “back-up” block to damage to the material. Always apply pressure in a straight line with the bit. Uses enough pressure to keep the drill biting, but do not push hard enough to stall the motor or defect the bit.

Hold tool firmly to control the twisting of the drill.

IF DRILL STALLS, it usually because it is being overloaded RELEASE TRIGGER IMMEDIATELY, removes drill from work, and determine cause of stalling. DO NOT CLICK TRIGGER OFF AND ON IN AN ATTEMPT TO START A STALLED DRILL - THIS CAN DAMAGE THE DRILL.

To minimize stalling or breaking through the material, reduce pressure on drill and ease the bit through the last fractional part of the hole.

Keep the motor running when pulling the bit back out of a drilled hole. This will help prevent jamming.

With variable speed drills there is no need to center punch the point to be drilled. Use a slow speed to start the hole is deep enough to drill without the bit skipping out. Operate at full on after starting the bit.

DRILLING IN WOOD

Holes in wood can be made with the same twist drills use for metal. These bits may overheat unless pulled out frequently to clear chips from the flutes. For large hole, use low speed wood bits. Work that is likely to splinter should be backed up with a block of wood.

DRILLING IN METALS

Use a cutting lubricant when drilling metals. The exceptions are cast iron and brass, which should be drilled dry. The cutting lubricants that work best are sulphurized cutting oil or lard oil; bacon grease also serves the purpose.

DRILLING MASONRY

Use carbide tipped masonry bits at low speeds. Keep even force on the drill but not so much that you crack brittle materials. A smooth, even flow of dust indicates the proper drilling rate.

OPERATION AS A SCREWDRIVER

Turn the river/Drill selector to the symbol of a screw. Select the desired speed/torque range using the dual range gear shifter on the top of tool to match the speed and torque to the planned operation. Insert the desired fastener accessory into the chuck as you would any drill bit. Make a few practice runs in scrap or unseen areas to determine the proper position of the clutch collar.

MAINTENANCE

CLEANING: With the motor running, blow dirt and dust out of all air vents with dry air at least once a week. Wear safety glasses when performing this. Exterior plastic parts may be cleaned a damp cloth and mild detergent. Although these parts are highly are solvent resistant, NEVER use solvent.

CHARGER CLEANING INSTRUCTIONS:

Dirt and grease may be removed from the exterior of the charger using a cloth or soft non-metallic brush. Do not use water or any cleaning solutions.

WARNING: Disconnect the charger from the AC outlet before cleaning solutions.

ACCESSORIES

Recommended accessories for use with your tool are available at extra cost from your local service center.

IMPORTANT! To assure product SAFETY and RELIABILITY, repairs, maintenance and adjustment (including brush inspection and replacement) should be performed by certified service centers or other qualified service organizations, always using identical replacement parts.

SPECIFICATION

Model Number	Volts	No Load Speed (rpm)	Torque (In.- lbs.)	Maximum Drilling Capacity (mm)			Charging Time	Tool Weight (lbs.)
				Mild Steel	Soft Wood	Concrete		
14DD	14.4V	0-360/0-1150	415	13	32	-	1 Hr	4.70
18HD	18V	0-400/0-1200	430	13	38	16	1 Hr	5.10

Warranty:

One year warranty on parts & labor from date of purchase. Receipt is required. Warranty does not cover abuse or negligence. Please contact your dealer for service.